

402-0007 Twinflex Weatherproof Manual Call Point

General Description

The Twinflex Weatherproof Manual Call Point (MCP) allows for user activation of the fire alarm system. Once operated the device latches into the alarm position and requires manually resetting via a special key. This device is compatible with the Twinflex 2-wire Fire Alarm Control Panel and comprises a 2-wire zone-powered MCP. This device may be installed on the same zone as the Twinflex Multipoint detector/sounder and other associated Twinflex devices. An optional clear front cover is available if required (Part No. 23-0187).

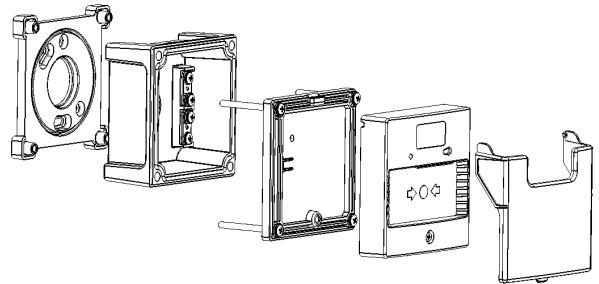

Before Installation

The MCP must be installed in compliance with the control panel installation manual. The installation must also meet the requirements of any local authority. For maximum performance the MCP should be installed in compliance with BS5839 Pt1 : 2002 + A2 : 2008.

Spacing

Fike recommends spacing of call points in accordance with BS5839 Pt1. For more specific information regarding MCP spacing, placement and special applications please refer to BS5839 Pt1 : 2002 + A2 : 2008.

Device Installation

All wiring must be installed in compliance with the recommendations laid out by BS5839 Pt1 : 2002 as well as any special recommendations documented in the control panel installation manual. The cabling used should be of a 2-core 1.5mm² screened, fire resistant type (e.g. MICC or FP200 equivalent), and is to be wired in the form of a screened 2-core radial circuit (with no spurs) from the control panel, terminating at the last ("End of Line") device.

Fix the wall mounting plate in a suitable position using the holes / slots. Drill out 20mm holes in back box in the required positions for cable glands.

Note: Holes must be clean and free of burrs and surface imperfections. This is critical for seal integrity. IP68 cable glands suitable for cable diameter used must be fitted in accordance with manufacturer's instructions to maintain the IP rating of the unit.

Fit the back box onto the wall mounting plate and terminate site cables into the connectors, as shown overleaf. Care should be taken when terminating devices to ensure all cables are correctly sleeved and connections are secure. Improper connections will prevent a system from responding properly in the event of a fire.

Please remember that all high voltage testing must be carried out before the installation of the MCP front unit otherwise the electronics will be damaged. Once all testing has been carried out on the cabling and **continuity & insulation** has been proven, the MCP can be connected.

Connect the wires from the MCP front into the appropriate terminals in the back box according to the wire colours. The MCP front can then be fitted by pushing the front Interface Plate onto the back box and tightening the four long fixing screws, before locating the upper mounting hook of the MCP front unit onto Interface Plate and then pushing the unit gently home. The single fixing screw may then be tightened.

Connections

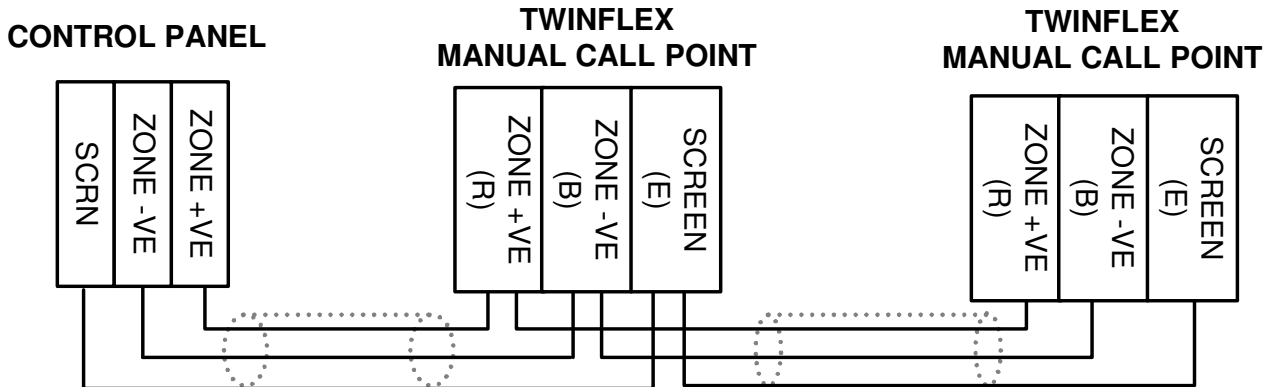
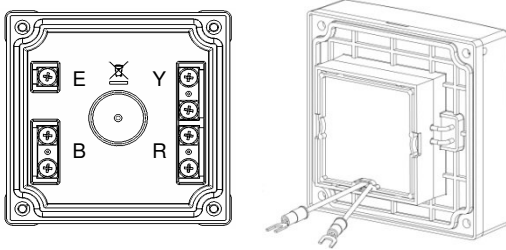

Note: Red = Zone +ve ; Blue = Zone -ve

Twinflex MCPs can be mixed on the same zone as other types of Twinflex device (eg. Twinflex Multipoint Detectors). The above diagram shows how to make the zone positive, zone negative and screen connections between the control panel and Twinflex MCPs. Refer to the instruction leaflets supplied with other Twinflex devices for their equivalent wiring/terminal labelling details.

Please note that the E terminal on the Call Points should only be connected to the zone cable screen and NOT to the building earth. The cable screen is connected to earth at the panel end only, via the zone "SCRN" terminal (or EARTH terminal on the Twinflex V3 2/4/8 Zone panels). It is important to maintain the screen continuity in order to protect against data corruption from interference.

Remember that the device at the end of the line must have its EOL signal activated using the relevant EOL switch. Do not use a resistor or capacitor (or another manufacturer's End of Line device) as the end of line, as this may prevent correct operation of the zone.

Reset and Test

The MCP contains a re-settable element, which latches in position when operated and does not need to be replaced. Inserting the key as shown and turning it clockwise until the element clicks back into place will reset the unit. Testing the MCP may be carried out either by pressing the element or by using the key in the same manner as for resetting but without having pressed the element.

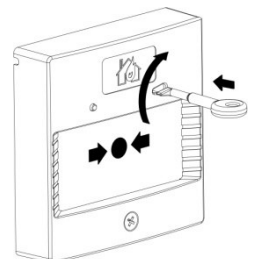

MCP DIL Switch Settings

The last device on the circuit must have its EOL signal enabled. Remove the cover as shown, then locate the switch and set it to 'ON'.

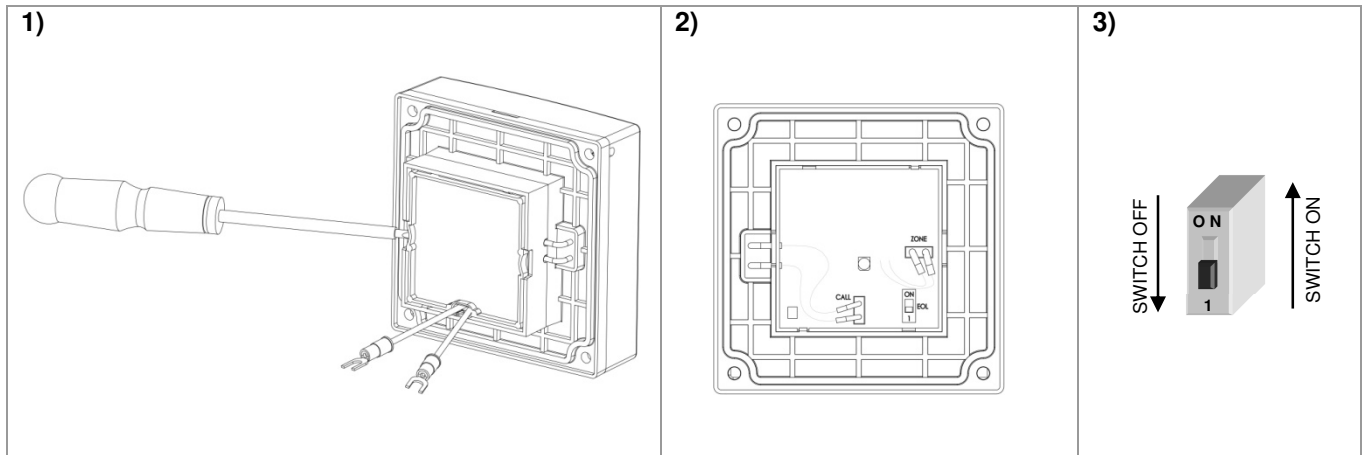

Technical Data

Dimensions	Width x Height	87mm x 87mm
	Depth	70mm
Operating Temperature	-10°C to +50°C.
Voltage Ranges	DC Output from Mains Powered Panel	25.5 to 35V DC
	DC Output from Battery Powered Panel	20 to 26V DC
Operating Current (Typical)	Quiescent	50 uA
	End of line ON if applicable	720 uA
	<i>(in addition to Quiescent)</i>	
LED Operation	Alarm Activated	16.5 mA
	Alarm Indication.....	Pulsed twice per second
	EOL indication	5 second interval
Loading Units		V3 Panel Pro Panel
	Max Loading Units per zone	27 SLU 160 DLU
	MCP.....	3.0 SLU 16.0 DLU
Flammability	UL94-V2
IP Rating	IP 65
Part Code	Twinflex MCP	402 0007

Technical Support

Contact your supplier for technical support on this product.

Due to the complexity and inherent importance of a life risk type system, training on this equipment is essential, and commissioning should only be carried out by competent persons. Fike cannot guarantee the operation of any equipment unless all documented instructions are complied with, without variation. This unit complies with the EMC directive.

Fike's policy is one of continual improvement and the right to change a specification at any time without notice is reserved. Whilst every care has been taken to ensure that the contents of this document are correct at time of publication, Fike shall be under no liability whatsoever in respect of such contents. E&OE.

 0832
Fike Safety Technology Ltd, 31 Springvale Ind Est, Cwmbran, UK. NP44 5BD (Manufactured Date on Product Label) 0832-CPD-1590
EN54-11 Fire Alarm Device – Callpoint Type A, Outdoor Use