

326-0021 Sita Sounder/Strobe with Low Profile Base

General Description

The Sita Sounder/Strobe unit allows for audible and visual indication when the system enters an alarm condition. This is an addressable unit that attaches to the loop. Digital communication technology to the control panel is implemented allowing for accurate data transfer at high transmission speeds. This device is only compatible with the Sita 200+, Duonet and Quadnet ranges of control panels.

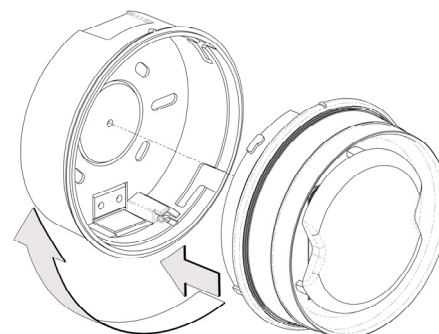

Before Installation

The Sounder/Strobe must be installed in compliance with the control panel installation manual. The installation must also meet the requirements of any local authority. For maximum performance the device should be installed in compliance with BS 5839 Pt1 : 2002 + A2 : 2008.

Spacing

Fike recommends spacing of sounders/strobes in accordance with BS 5839. For more specific information regarding sounder spacing, placement and special applications please refer to BS 5839 Pt1 : 2002 + A2 : 2008.

Device Installation

The base moulding should be positioned so that access to the locking feature is concealed from general view to lessen the possibility of unauthorised removal of the device.

Drill or break out the cable entry region(s) in the base moulding as required.

Drill out the desired mounting holes through hole / slot guides as required. Affix the base moulding to a flat surface using a minimum of 2 screws.

All wiring must be installed in compliance with the recommendations laid out by BS 5839 as well as any special recommendations documented in the control panel installation manual. **The cabling used should be of a 2-core 1.5mm² screened, fire resistant type, with the following characteristics:**

Max Capacitance Core to Screen.....	180pF / m
Max Capacitance Core to Core	100pF / m
Max Inductance	1.0mH / km
Max Resistance Two Core Screened 1.5mm ²	12.1Ω / km

It is to be wired in the form of a screened 2-core loop returning to the control panel. The use of spurs on this system is not permitted. Cables may be terminated into the connector, as shown below. Care should be taken when terminating devices to ensure all cables are correctly sleeved and connections are secure. Improper connections will prevent a system from responding properly in the event of a fire.

Terminal	Description
L1	Loop +ve IN
0V	Loop -ve IN
SCRN	Screen IN
SCRN	Screen OUT
0V	Loop -ve OUT
L2	Loop +ve OUT

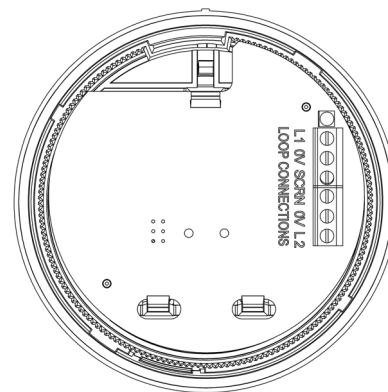

The Loop +ve (positive) IN and the Loop +ve (positive) OUT connections are split within the module. For cable continuity readings at the commissioning stage they must be temporarily removed and connected through. Please remember that all high voltage testing must be carried out before the installation of the electronics, otherwise the electronics will be damaged. Please also note that the SCR terminal should only be connected to the loop screen and NOT the building earth.

Once all testing has been carried out on the cabling and **continuity & insulation** has been proven, the Sounder/Strobe unit can be assembled.

NOTE: Before installing the Sounder/Strobe remember to note the serial number of the device (located on the rear of the unit) on to your drawings or configuration sheets to enable you to prove its location later. The address allocation for the device is carried out automatically by the control panel whilst in initialisation mode, so addresses do not need to be set manually. See the system Installation and Operating Instructions for further details.

Tamper Resistance

The unit incorporates a locking mechanism which helps prevent unauthorised removal from the base. To fit, gently insert the device positioned so that the alignment mark on rim is rotated slightly anti clockwise relative to the alignment mark on the base. Rotate clockwise until the device drops in and the alignment marks meet. The locking clip will click.

To remove the device: depress the locking clip by inserting a small diameter tool, such as a jeweller's screwdriver, through the hole in the base as shown.

The device should then be turned anti-clockwise allowing it to be removed from the base.

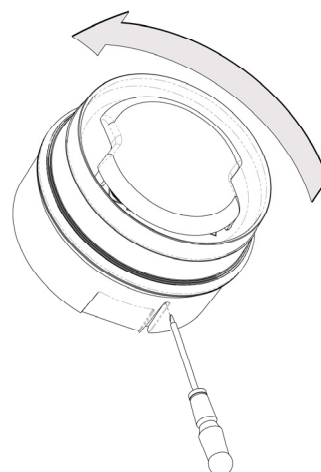

Device Settings

The sounder modes may be configured using the relevant panel software configuration package.

	Type	Description
Sound Pattern:	SP0	Sounder off
	SP1	Single tone, 970 Hz continuous
	SP2	Pulsed UK alert signal, 970 Hz 1s on, 1s off
	SP3	Dual tone UK evacuate signal, 970 Hz 0.25s, 800 Hz 0.25s
	SP4	This sound pattern is not supported in this product
	SP5	Slow whoop up, 500 to 1200 Hz over 3s, 0.5s off
	SP6	Sweep down, 1200 Hz to 500 Hz over 1s
	SP7	Dual tone French warble, 550 Hz 0.1s, 440 Hz 400ms
Sound Volume:	L/M/H	Low, medium and high settings are available. See the Control Panel Engineering and Commissioning Instructions for further details

See the Engineering & Commissioning Manual for your control panel (Sita, Duonet or Quadnet) for further details of how to program the above.

Beacon Operation

The unit includes a Visual Indication Beacon. This consists of a number of high output LEDs.

The beacon will start to operate when the device receives a command to activate its sounder, even if the sound pattern is set to **SP0 - Sounder off**. If the beacon only is required to operate, Sound Pattern SP0 must be selected via the configuration software.

Power Up

The Sita Sounder/Strobe requires approximately one minute on power up to boot up its processor, charge for alarm operation and settle down to normal operation. Do not sound the alarms within the first minute after initializing the loop.

Technical Data

Dimensions:	Diameter	97 mm
	Depth: inc low profile base	60.5 mm
Operating temperature:		-10°C to +50°C.
Flammability:		UL94-V2
IP Rating:		IP 21C
Voltage Range (Loop):		24 to 42V DC
System Compatibility:	Sita 200 plus V2.30 onwards.	
	Duonet and Quadnet V1 onwards.	

PRODUCT DESCRIPTION			VOLUME LEVEL (dBA) @ 1m anechoic (Dual Tone)		
Type	Product Code	Name	Low	Medium	High
SNDR	326 0021	Sita Sounder / Strobe with Low Profile Base	65+	84	88

			LOOP CURRENT (mA)				
Type	Product Code	Name	Quiescent	SP0 - Off	Low	Medium	High
SNDR	326 0021	Sita Sounder / Strobe with Low Profile Base	0.18	9.00	9.50	11.50	13.50

			BATTERY CURRENT (mA)				
Type	Product Code	Name	Quiescent	SP0 - Off	Low	Medium	High
SNDR	326 0021	Sita Sounder / Strobe with Low Profile Base	0.18	18.75	19.80	23.96	28.13

			DLU RATING			
Type	Product Code	Name	SP0 - Off	Low	Medium	High
SNDR	326 0021	Sita Sounder / Strobe with Low Profile Base	9	9.5	11.5	13.5

N.B. All specified volume and current readings, unless otherwise stated are taken using sound pattern SP3.

Sita OSP versions prior to v4.05A and Quadnet/Duonet OSP versions prior to v2.02A do not include the above DLUs. Manual loop loading and battery backup calculations may therefore be required.

Technical Support

Contact your supplier for technical support on this product.

Due to the complexity and inherent importance of a life risk type system, training on this equipment is essential, and commissioning should only be carried out by competent persons. Fike cannot guarantee the operation of any equipment unless all documented instructions are complied with, without variation. This unit complies with the EMC directive.

Fike's policy is one of continual improvement and the right to change a specification at any time without notice is reserved. Whilst every care has been taken to ensure that the contents of this document are correct at time of publication, Fike shall be under no liability whatsoever in respect of such contents. E&OE.



0832

Fike Safety Technology Ltd,
31 Springvale Ind Est,
Cwmbran, UK. NP44 5BD

(Manufactured Date on Product Label)

0832-CPD-1581

EN54-3 Fire Alarm Device – Sounder
Type A – Indoor Use
EN54-17 Fire Alarm Device – Isolator

Sounder Technical Data: See 26-0747
Isolator Technical Data: See 26-1112