

© Apollo Fire Detectors Limited 2003-7/JDR/IP



DIN-Rail Mounted Dual Isolator Installation Guide

General

The DIN-Rail Mounted Dual Isolator, part no. 55000-802, is designed to be mounted in an enclosure, clipped onto a standard 35mm DIN Rail (DIN 46277) and secured using end stops.

Suitable enclosures are available from Apollo, part nos 29600-239 (4 way) and 29600-240 (10 way).

The installation must conform to BS5839 (or applicable local codes) and be carried out such that the unit is not

- exposed to risk of mechanical damage
- exposed to unauthorised modification or interference
- exposed to moisture, dust and foreign bodies
- exposed to temperatures exceeding the maximum ambient

Installation

1. Run the cables from the loop into the unit. Ensure that earth continuity is maintained.
2. Clip the unit to the standard 35mm DIN rail (DIN 46277). Please use end stops, part no. 27447-528 or equivalent, at each end of the unit to secure it in place.

Wiring Details

All wiring terminals accept solid or stranded cables up to 2.5mm².

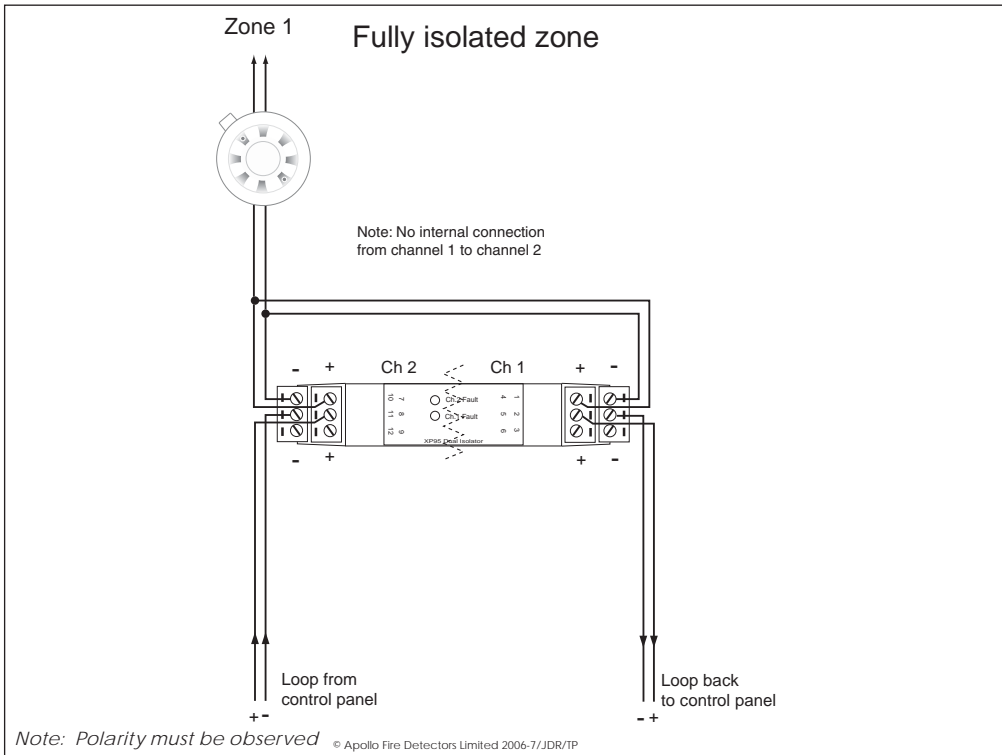
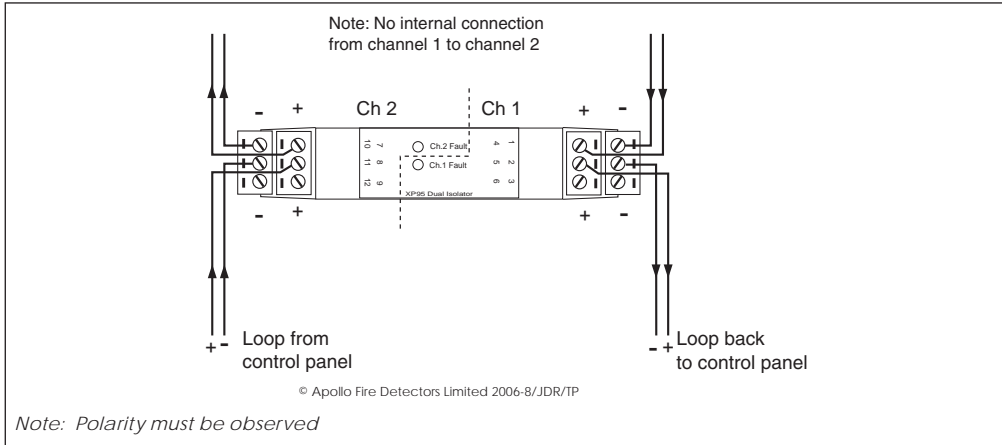

Electrical Characteristics

Max supply voltage	28V DC + 9V protocol pulses
Quiescent current	47µA at 28V
Max current (through loop)	4mA when isolating
Isolating voltage	1A continuous, 3A peak 14V

Commissioning

Commission the fire detection system in accordance with local codes and the panel manufacturer's instructions. With the system in the normal operating condition, apply short-circuits to the loop wiring at selected points between isolators. Verify that isolators function correctly.

LED Indicators

- ⊙ Ch 2 Fault Illuminated when loop wiring to Ch 2 is short-circuit
- ⊙ Ch 1 Fault Illuminated when loop wiring to Ch 1 is short-circuit

Troubleshooting

Before investigating individual units for faults, it is important to check that the system wiring is fault free. Earth faults on data loops or interface zone wiring may cause communication error. Many fault conditions are the result of simple wiring errors. All connections to the unit should be checked. For a full technical description refer to the DIN-Rail Mounted Dual Isolator Pin Sheet, PP2051-T.

Fault Finding

Problem	Possible Cause
Loop short-circuit	Isolator connected in reverse polarity
No supply on loop output	Incorrect isolator wiring
Unit does not isolate when loop shorted	Incorrect isolator wiring High resistance in loop wiring

End stops

End stops are used to secure the unit in place. One is to be used at each end of the unit. If multiple DIN Rail units are being used then an end stop at each end of the row of units is acceptable.